



120 V – 60 Hz
230 V – 50/60 Hz

(Available with country specific plug configurations & additional accessories)

Main Applications

Laboratory Environments

Small labs that do not have access to facility air

- Diagnostics – Flow Cytometry
- Analytical Instruments
- Sample Management in automated system
- Zero air generator air supply
- Isolation table
- General small lab air use

Medical Environments

Hospital and Medical office use applications:

- Endoscopy
- Autoclave
- Medical Rehabilitation

Industrial Applications

Facilities that need access to small and portable air system

- Small pneumatic tool operation
- Food preparation and packaging
- Beverage dispensing
- Air cylinders operation in automated systems

Trouble-free and built to last

- New motor design for optimum reliability
- Optimized cooling configuration
- 10000+ hours piston seal life
- Designed to run at 100% duty cycle

Powerful & Quiet Performance

- 120 psi / 8 bar capability
- 3.2 cfm / 91 l/min max air flow
- 63 dB(A) utilizing optimized component positioning and efficient air inlet muffler

Clean Air

- 100% oil free operation
- 5µm filter regulator in standard configuration
- 0.01µm filter option

Easy to install and use

- Designed with space limitations in mind
- Integrated handle to transport and motor protection

Global support

- Global service network
- 2 year warranty / 5 year tank warranty
- UL 1450 / CSA / CE compliance



Product Specifications

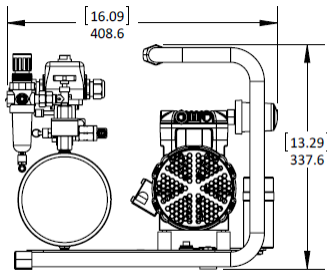
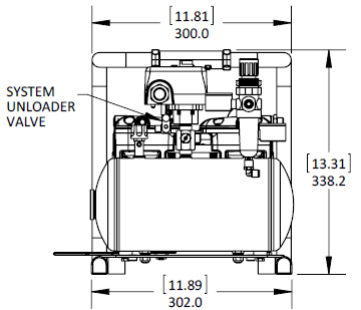

Air Flow

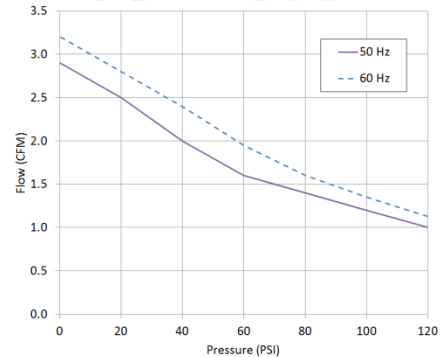
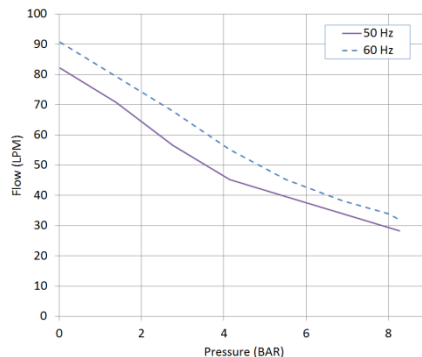

Features

- 100% oil free
- 100% duty cycle
- quiet operation 61/63dBA
- pressure up to 120 PSI
- long-life, 2-year warranty
- >10,000 hours cup life
- easy to use
- plug & play

Description

- 5µm filter regulator with automatic drain
- handle for transport and motor protection
- receiver with internal coating and 5-year warranty

Options

- 0.01µm filter
- receiver automatic drain with bottle

Certifications



- UL 1450
- cUL (CAN ISCA C22.2, No. 68-09)
- CE (97/23/EC, 2004/108/EC, 2006/95/EC, 2011/65/EU)

Model	87R-4B			
Voltage	V	1x120	1x230	1x230
Frequency	Hz	60	50	60
Motor	HP	0.5	0.5	0.5
	kW	0.37	0.37	0.37
Displacement	l/min	91	82	91
	cfm	3.2	2.9	3.2
Air flow @ 8bar / 120 psi	l/min	34	28	34
	cfm	1.2	1	1.2
Max. pressure	bar	8	8	8
	psi	120	120	120
Max. current	A	5.7	2.5	2.8
Receiver volume	litres	4	4	4
	gallon	1.05	1.05	1.05
Weight	kg	18	18	18
	lbs	40	40	40
Noise level	dB(A)/1m	63	61	63
Thermal protection		Yes	Yes	Yes
Duty cycle		100%	100%	100%